

NV156FHM-T06**Preliminary Product Specification****Rev. P0****BOE Optoelectronics Technology Co., Ltd**

REVISION HISTORY

| Revision No. | Page | Description of Changes | Date | Prepared |
|--------------|------|-----------------------------------|-------|----------|
| 0 | 37 | Initial Release | 9/30 | Zilei |
| P0 | 12 | Update 4.2 Optical Specifications | 11/30 | Zilei |
| | | | | |
| | | | | |
| | | | | |

REVIEWED

| Designer | Manager |
|------------------------|--------------|
| Zhang Shouqiang(Array) | Wang Xiaolin |
| Pan Ruiqi (Cell) | Hu Jingyong |
| Qiao Zonghua(CF) | Li Min |
| Luo Zhongli(EE) | Zuo Cheng |
| Liu Song(MO) | Gao Liang |
| Mou Binkai(QE) | Huang Yuan |

APPROVED

Zilei(PM)

Contents

| No. | Items | Page |
|------|--|------|
| 1.0 | General Description | 4 |
| 2.0 | Absolute Maximum Ratings | 7 |
| 3.0 | Electrical Specifications | 8 |
| 4.0 | Optical Specifications | 12 |
| 5.0 | Interface Connection | 17 |
| 6.0 | Signal Timing Specification | 21 |
| 7.0 | Input Signals, Display Colors & Gray Scale of Colors | 23 |
| 8.0 | Power Sequence | 24 |
| 9.0 | Connector Description | 26 |
| 10.0 | Mechanical Characteristics | 27 |
| 11.0 | Reliability Test | 28 |
| 12.0 | Handling & Cautions | 28 |
| 13.0 | Label | 29 |
| 14.0 | Packing Information | 31 |
| 15.0 | Mechanical Outline Dimension | 32 |
| 16.0 | EDID Table | 34 |

1.0 GENERAL DESCRIPTION

1.1 Introduction

NV156FHM-T06 is a color active matrix TFT LCD module using amorphous silicon TFT's (Thin Film Transistors) as an active switching devices. This module has a 15.6 inch diagonally measured active area with Full-HD resolutions (1920 horizontal by 1080 vertical pixel array). Each pixel is divided into RED, GREEN, BLUE dots which are arranged in vertical stripe and this module can display 262k(6bit) colors and color gamut 45%. The TFT-LCD panel used for this module is a low reflection and higher color type. Therefore, this module is suitable for Notebook PC. The LED driver for back-light driving is built in this model.

All input signals are eDP1.2 interface compatible.

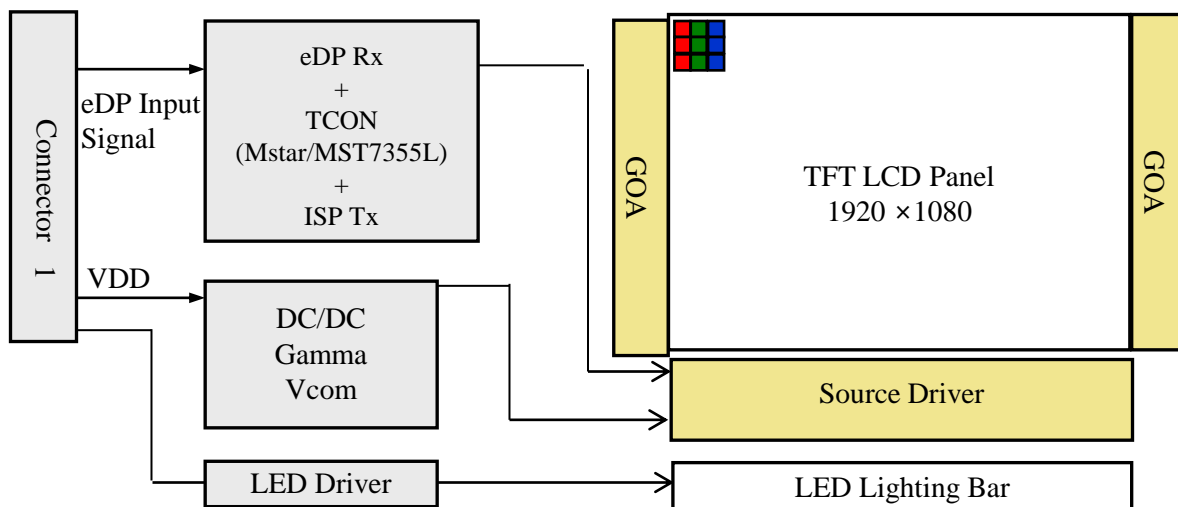

Figure 1. Drive Architecture

1.2 Features

- 2 lane eDP interface with 2.7Gbps link rates
- Thin and light weight
- 262k(6bit) color depth, color gamut 45%
- Single LED lighting bar (Bottom side/Horizontal Direction)
- Data enable signal mode
- Side mounting frame
- Green product (RoHS & Halogen free product)
- On board LED driving circuit
- Low driving voltage and low power consumption
- On board EDID chip

1.3 Application

- Notebook PC (Wide type)

1.4 General Specification

The followings are general specifications at the model NV156FHM-T06. (listed in Table 1)

<Table 1. General Specifications>

| Parameter | Specification | Unit | Remarks |
|---------------------|---|--------|---------|
| Active area | 344.16(H) × 193.59(V) | mm | |
| Number of pixels | 1920 (H) × 1080 (V) | pixels | |
| Pixel pitch | 179.25(H) × 179.25(V) | um | |
| Pixel arrangement | RGB Vertical stripe | | |
| Display colors | 262k(6bit) | | |
| Color gamut | 45% | | NTSC |
| Display mode | Normally black | | |
| Dimensional outline | 350.66(H) × 216.15(V) (W/PCB) × 3.2max(panel side) 3.4max(PCBA side) | mm | |
| Weight | 385 (max) | g | |
| Surface treatment | HC | | |
| Surface hardness | 3H | | |
| Back-light | Bottom edge side, 1-LED lighting bar type | | Note 1 |
| Power consumption | P _D : 0.9 | W | @Mosaic |
| | P _{BL} : 3.6 | W | |
| | P _{Total} : 4.5 | W | @Mosaic |

Notes : 1. LED Lighting Bar (40*LED Array)

1.2.2.General Touch Specification(Table 2.)

<Table 2. General Touch Specifications>

| Parameter | Specification | Unit | Remarks |
|-----------------------|----------------------------|------|------------|
| Type of Touch Sensor | Self Capacitance | | |
| Touch Structure | On Cell | | |
| Panel Size | 15.6" | | |
| Outline Dimension | N/A(Cover Lens Free) | mm | |
| TP View Area | N/A(Cover Lens Free) | mm | |
| TP Active Area | X 345.96 × Y 193.74 (AA) | mm | |
| Total Thickness | N/A(Cover Lens Free) | mm | |
| Interface | I2C | | |
| Report Rate | Follow win8/10 ≥ 100 | Hz | |
| Multi-Touch Point | 10 points | | |
| Input method | Finger | | |
| Touch panel sensor IC | G7500 | | G2 Touch |
| Channel | 1500 | | |
| Surface treatment | HC | | |
| Surface Hardness | 3 | H | |
| Support OS | Win8.x and Win10 compliant | | |
| TP Power Consumption | 0.2max. | W | @ 5 finger |

2.0 ABSOLUTE MAXIMUM RATINGS

The followings are maximum values which, if exceed, may cause faulty operation or damage to the unit. The operational and non-operational maximum voltage and current values are listed in Table 2.

< Table 2. Absolute Maximum Ratings >

Ta=25+/-
2° C

| Parameter | Symbol | Min. | Max. | Unit | Remarks |
|-----------------------|-----------------|----------------------|----------------------|------|---------|
| Power Supply Voltage | V _{DD} | -0.3 | 4.0 | V | Note 1 |
| Logic Supply Voltage | V _{IN} | V _{SS} -0.3 | V _{DD} +0.3 | V | |
| Operating Temperature | T _{OP} | 0 | +50 | ° C | Note 2 |
| Storage Temperature | T _{ST} | -20 | +60 | ° C | |

Notes :

1. Permanent damage to the device may occur if maximum values are exceeded functional operation should be restricted to the condition described under normal operating conditions.
2. Temperature and relative humidity range are shown in the figure below.
95 % RH Max. (40 ° C ≥ Ta) Maximum wet - bulb temperature at 39 ° C or less. (Ta > 40 ° C) No condensation.

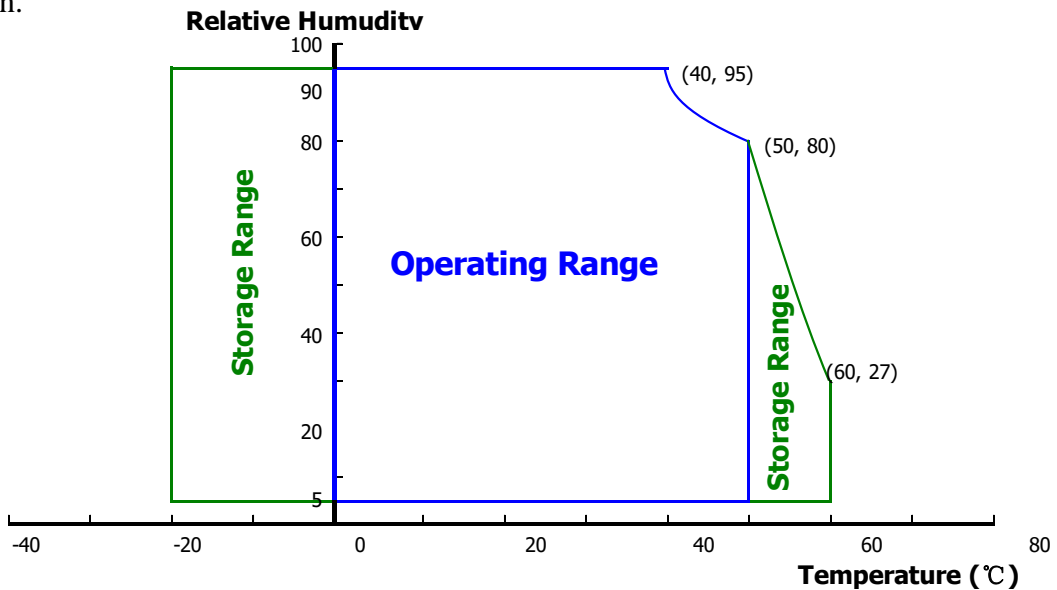

Figure 2. Temperature and Relative Humidity Range

3.0 ELECTRICAL SPECIFICATIONS

3.1 Electrical Specifications

< Table 3. Electrical Specifications >

Ta=25+/-2°C

| Parameter | | Min. | Typ. | Max. | Unit | Remarks |
|----------------------------------|---------------------|-------------------------|------|-------------------------|------|---------|
| Power Supply Voltage | V _{DD} | 3.0 | 3.3 | 3.6 | V | Note 1 |
| Permissible Input Ripple Voltage | V _{RF} | 10%* V _{DD} | - | 10%* V _{DD} | mV | Note4 |
| BIST Control Level | High Level | 2 | - | 3.6 | V | - |
| | Low Level | 0 | - | 0.8 | V | - |
| Power Supply Current | I _{DD} | - | 273 | 485 | mA | Note 1 |
| Power Supply Inrush Current | I _{inrush} | - | - | 1.5 | A | Note3 |
| Power Consumption | P _D | - | 0.9 | 1.6 | W | Note 1 |
| | P _{BL} | - | - | 3.6 | W | Note 2 |
| | P _{total} | - | - | 5.2 | W | Note1 |

Notes :

- The supply voltage is measured and specified at the interface connector of LCM.
The current draw and power consumption specified is for 3.3V at 25 °C.

- Typ : Mosaic pattern 8*8
- Max : R/G/B patterns



(a)



(b)

Figure 3. Power Measure Patterns

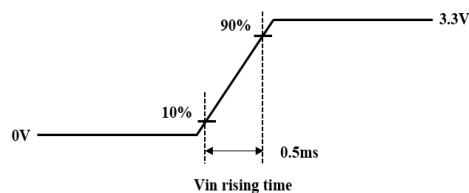

Figure 4. Inrush Measure Condition

- Calculated value for reference (V_{LED} × I_{LED})
- Measure condition (Figure 4)
- Input voltage range: 3.0~3.6V. Test condition :Oscilloscope bandwidth 20MHz , Ac coupling

3.1.2 Touch Electrical Specifications

< Table 5. Electrical specifications >

| Parameter | | Min. | Typ. | Max. | Unit | Remarks | |
|----------------------------------|-------------|----------|---------------|------|---------------|---------|--------------------|
| Power Supply Voltage | | V_{DD} | 3.0 | 3.3 | 3.6 | V | Note 1 |
| Permissible Input Ripple Voltage | | V_{RF} | - | - | 100 | mV | At $V_{DD} = 3.3V$ |
| Power Supply Current | | I_{DD} | - | - | 61 | mA | |
| Power Consumption | Active Mode | P_T | - | - | 0.2 | W | Note1 |
| | Idle Mode | | - | - | 0.1 | W | Note2 |
| TP_EN | High Level | | 0.7*V DDIO | - | - | V | Note3 |
| | Low Level | | - | - | 0.3*V DDIO | V | |

- Notes :
1. The supply voltage is measured and specified at the interface connector of TLCM
The current draw and power consumption specified is for 3.3V at 25°C when touch function is active;
 2. The supply voltage is measured and specified at the interface connector of TLCM
The current draw and power consumption specified is for 3.3V at 25°C when touch function is Idle;
 3. Condition: 1.62 V < VDDIO < 3.6 V;

3.2 Backlight Unit

< Table 4. LED Driving Guideline Specifications >

Ta=25+/-2°C

| Parameter | | Min. | Typ. | Max. | Unit | Remarks |
|--|-------------------------|--------|------|--------|------|-------------------------|
| LED Forward Voltage | V _F | - | - | 3.0 | V | - |
| LED Forward Current | I _F | - | 23.4 | - | mA | - |
| LED Power Consumption | P _{LED} | - | - | 3.6 | W | Note 1 |
| LED Life-Time | N/A | 15,000 | - | - | Hour | I _F = 23.4mA |
| Power Supply Voltage for LED Driver | V _{LED} | 5 | 12 | 21 | V | - |
| Power Supply Voltage for LED Driver Inrush | I _{led inrush} | - | - | 1.5 | A | Note 4 |
| EN Control Level | Backlight On | 2.5 | - | 5.0 | V | - |
| | Backlight Off | 0 | - | 0.8 | V | - |
| PWM Control Level | High Level | 2.5 | - | 5.0 | V | - |
| | Low Level | 0 | - | 0.8 | V | - |
| PWM Control Frequency | F _{PWM} | 200 | - | 10,000 | Hz | - |
| Duty Ratio | | 1 | - | 100 | % | Note 3 |

Notes :

1. Power supply voltage 12V for LED driver.

Calculator value for reference $I_F \times V_F \times 40 / \text{driver efficiency} = P_{LED}$

2. The LED life-time define as the estimated time to 50% degradation of initial luminous.

3. 1% duty cycle is achievable with a dimming frequency less than 1KHz.

4. Measure condition (Figure 5)

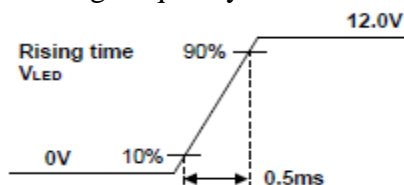

Figure 5. Inrush Measure Condition

3.3 LED Structure

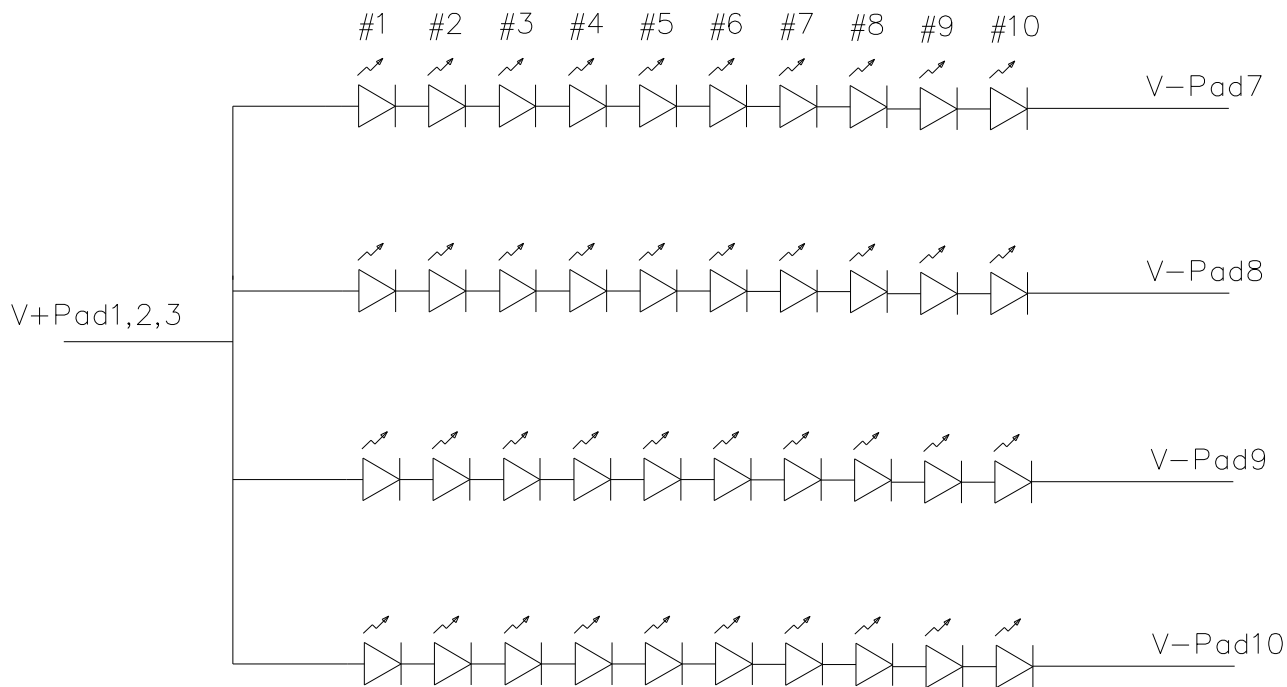

Figure 6. LED Structure

4.0 OPTICAL SPECIFICATION

4.1 Overview

The test of optical specifications shall be measured in a dark room (ambient luminance ≤ 1 lux and temperature = $25 \pm 2^\circ\text{C}$) with the equipment of luminance meter system (PR730&PR810) and test unit shall be located at an approximate distance 50cm from the LCD surface at a viewing angle of θ and Φ equal to 0° . We refer to $\theta=0$ ($=\theta_3$) as the 3 o'clock direction (the "right"), $\theta=90$ ($=\theta_{12}$) as the 12 o'clock direction ("upward"), $\theta=180$ ($=\theta_9$) as the 9 o'clock direction ("left") and $\theta=270$ ($=\theta_6$) as the 6 o'clock direction ("bottom"). While scanning θ and/or Φ , the center of the measuring spot on the display surface shall stay fixed. The backlight should be operating for 30 minutes prior to measurement. VDD shall be $3.3 \pm 0.3\text{V}$ at 25°C . Optimum viewing angle direction is 6 o'clock.

4.2 Optical Specifications

<Table 5. Optical Specifications>

| Parameter | | Symbol | Condition | Min. | Typ. | Max. | Unit | Remark |
|----------------------------------|------------|-----------------|---|-------|-------|-------|-------------------|--------|
| Viewing Angle Range | Horizontal | Θ_3 | CR > 10 | 80 | 85 | - | Deg. | Note 1 |
| | | Θ_9 | | 80 | 85 | - | Deg. | |
| | Vertical | Θ_{12} | | 80 | 85 | - | Deg. | |
| | | Θ_6 | | 80 | 85 | - | Deg. | |
| Luminance Contrast Ratio | | CR | $\Theta = 0^\circ$ | 600 | 800 | - | | Note 2 |
| Luminance of White | 5 Points | Y_w | $\Theta = 0^\circ$ $I_{LED} = 23.4\text{mA}$ | 212.5 | 250 | - | cd/m ² | Note 3 |
| White Luminance Uniformity | 5 Points | ΔY_5 | | 80 | - | - | % | Note 4 |
| | 13 Points | ΔY_{13} | | 62.5 | - | - | % | |
| White Chromaticity | | W_x | $\Theta = 0^\circ$ | 0.283 | 0.313 | 0.343 | - | Note 5 |
| | | W_y | | 0.299 | 0.329 | 0.359 | - | |
| Reproduction of Color | Red | R_x | $\Theta = 0^\circ$ | -0.03 | 0.590 | +0.03 | - | - |
| | | R_y | | | 0.350 | | - | - |
| | Green | G_x | | | 0.330 | | - | - |
| | | G_y | | | 0.555 | | - | - |
| | Blue | B_x | | | 0.153 | | - | - |
| | | B_y | | | 0.119 | | - | - |
| Color Gamut | | - | - | - | 45 | - | % | - |
| Response Time (Rising + Falling) | | T_{RT} | $T_a = 25^\circ\text{C}$ $\Theta = 0^\circ$ | - | 16 | 20 | ms | Note 6 |
| Cross Talk | | CT | $\Theta = 0^\circ$ | - | - | 2.0 | % | Note 7 |

Notes :

1. Viewing angle is the angle at which the contrast ratio is greater than 10. The viewing angles are determined for the horizontal or 3, 9 o'clock direction and the vertical or 6, 12 o'clock direction with respect to the optical axis which is normal to the LCD surface (see Figure 7).
2. Contrast measurements shall be made at viewing angle of $\Theta = 0$ and at the center of the LCD surface. Luminance shall be measured with all pixels in the view field set first to white, then to the dark (black) state . (see Figure 7) Luminance Contrast Ratio (CR) is defined mathematically.

$$CR = \frac{\text{Luminance when displaying a white raster}}{\text{Luminance when displaying a black raster}}$$
3. Center Luminance of white is defined as luminance values of 5 point average across the LCD surface. Luminance shall be measured with all pixels in the view field set first to white. This measurement shall be taken at the locations shown in Figure 8 for a total of the measurements per display.
4. The White luminance uniformity on LCD surface is then expressed as : $\Delta Y = \text{Minimum Luminance of 5(or 13) points} / \text{Maximum Luminance of 5(or 13) points.}$ (see Figure 8 and Figure 9).
5. The color chromaticity coordinates specified in Table 5 shall be calculated from the spectral data measured with all pixels first in red, green, blue and white. Measurements shall be made at the center of the panel.
6. The electro-optical response time measurements shall be made as Figure 10 by switching the “data” input signal ON and OFF. The times needed for the luminance to change from 10% to 90% is T_r , and 90% to 10% is T_f .
7. Cross-Talk of one area of the LCD surface by another shall be measured by comparing the luminance (YA) of a 10 ± 1 mm diameter area, with all display pixels set to gray 127(of 0 to 255), to the luminance (YB) of that same area when any adjacent area is driven dark. The luminance ratio shall not exceed 1:1.05 (See Figure 11).

4.3 Optical Measurements

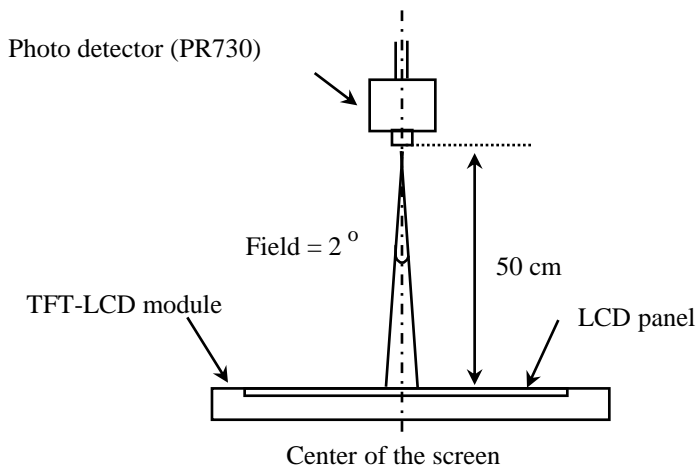

Optical characteristics measurement setup

Figure 7. Measurement Set Up

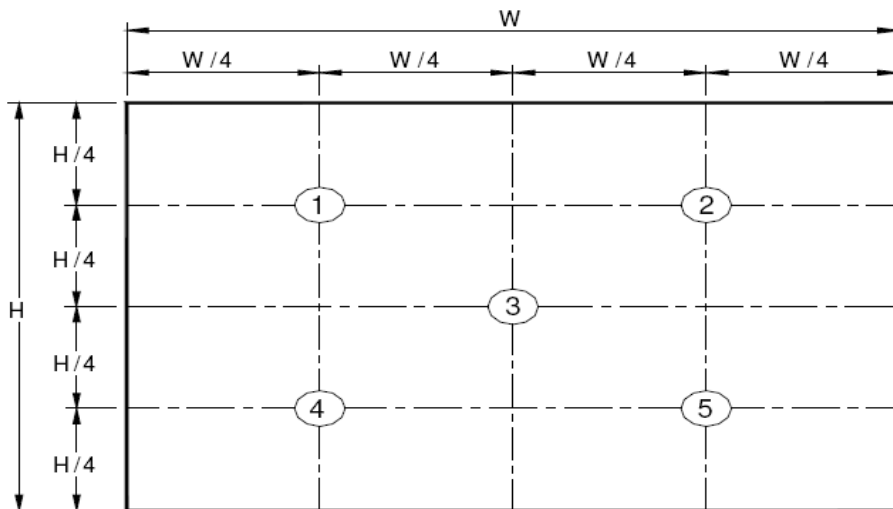

Figure 8. White Luminance and Uniformity Measurement Locations (5 points)

Center Luminance of white is defined as luminance values of center 5 points across the LCD surface. Luminance shall be measured with all pixels in the view field set first to white. This measurement shall be taken at the locations shown in Figure 7 for a total of the measurements per display.

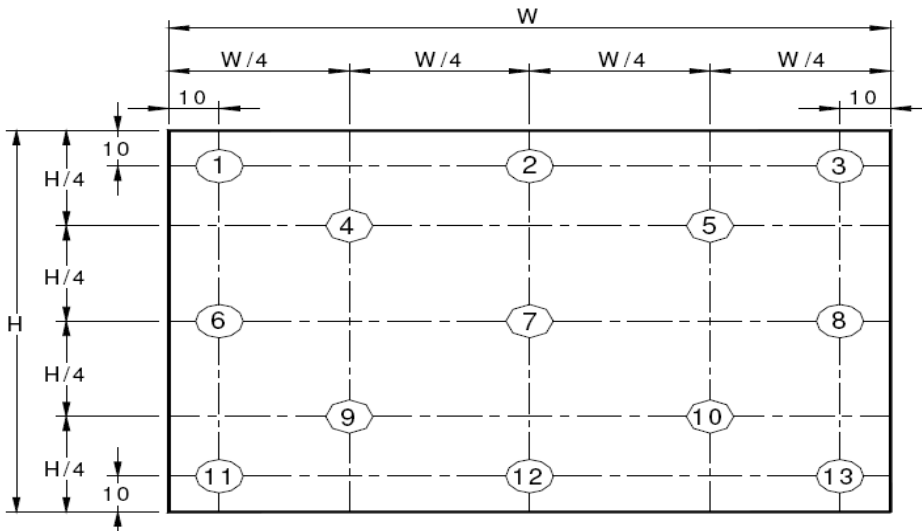

Figure 9. Uniformity Measurement Locations (13 points)

The White luminance uniformity on LCD surface is then expressed as : $\Delta Y5 = \text{Minimum Luminance of five points} / \text{Maximum Luminance of five points}$ (see Figure 8) , $\Delta Y13 = \text{Minimum Luminance of 13 points} / \text{Maximum Luminance of 13 points}$ (see Figure 9).

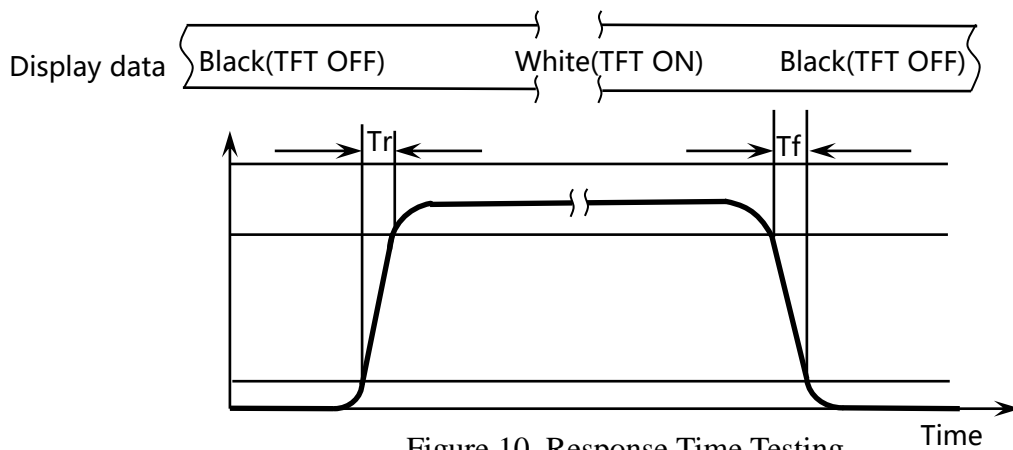
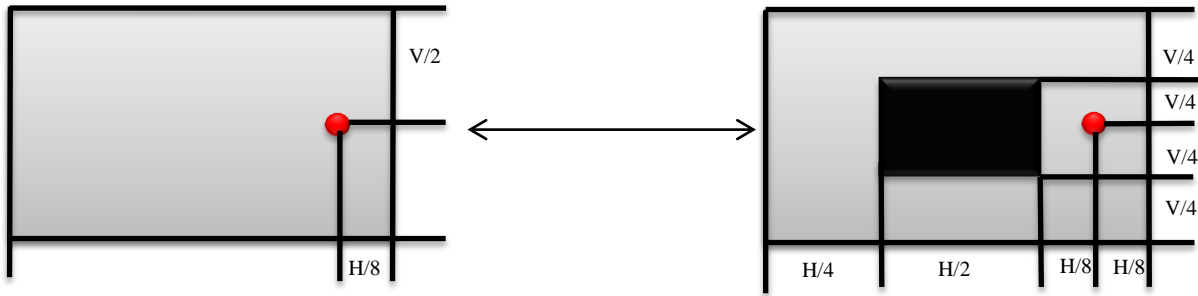

Figure 10. Response Time Testing

The electro-optical response time measurements shall be made as shown in Figure 10 by switching the “data” input signal ON and OFF. Tf: The luminance to change from 90% to 10% ,Tr: The luminance to change from 10% to 90% .

The test system : PR810



$$\text{Cross Talk (\%)} = \left| \frac{Y_B - Y_A}{Y_B} \right| \times 100$$

Figure 11. Cross Talk Modulation Test Description

Where:

Y_A = Initial luminance of measured area (cd/m²)

Y_B = Subsequent luminance of measured area (cd/m²)

The location 1/2/3/4 measured will be exactly the same in both patterns. The test background gray is from L64 to L192. Take the largest data as the result.

Cross Talk of one area of the LCD surface by another shall be measured by comparing the luminance (Y_A) of a 25mm diameter area, with all display pixels set to a gray level, to the luminance (Y_B) of that same area when any adjacent area is driven dark. (Refer to Figure 11)

The test system: PR730

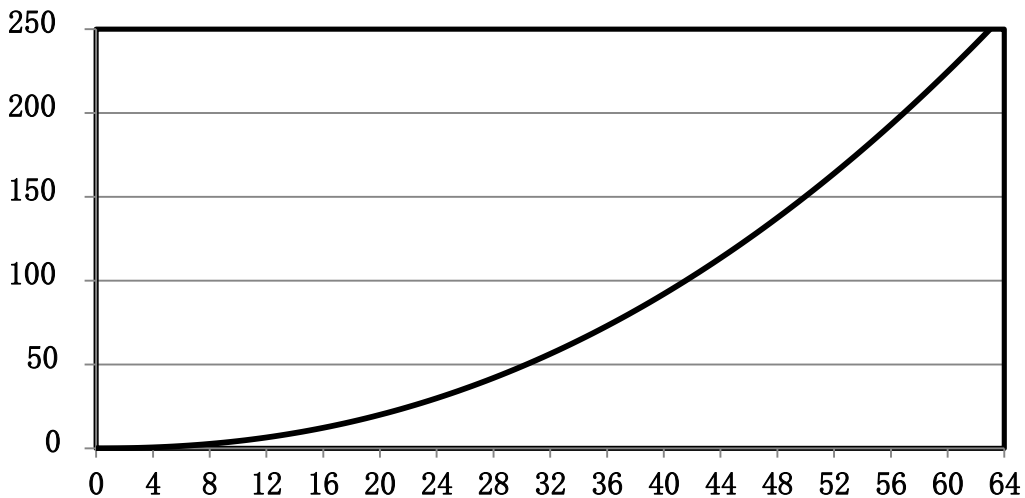

Figure 12. Brightness and Gray-scale Contrast

5.0 INTERFACE CONNECTION

5.1 Electrical Interface Connection

The electronics interface connector is 20455-040E-66.

The connector interface pin assignments are listed in Table 6.

<Table 6. Pin Assignments for the Interface Connector>

| PIN NO | Symbol Function | Description | PIN NO | Symbol Function | Description |
|--------|---------------------|---------------------------------------|--------|-----------------|------------------------------------|
| 1 | DCR Enable Function | DCR Enable Function | 21 | BL_GND | Backlight ground |
| 2 | H_GND | High Speed Ground | 22 | BL_Enable | Backlight On / Off |
| 3 | Lane1_N | Comp Signal Link Lane 1 | 23 | BL_PWM_DIM | System PWM signal Input |
| 4 | Lane1_P | True Signal Link Lane 1 | 24 | NC | No connect (Reverse for TEST only) |
| 5 | H_GND | High Speed Ground | 25 | NC | No connect (Reverse for TEST only) |
| 6 | Lane0_N | Comp Signal Link Lane 0 | 26 | BL_PWR | Backlight power (5V~21V) |
| 7 | Lane0_P | True Signal Link Lane 0 | 27 | BL_PWR | Backlight power (5V~21V) |
| 8 | H_GND | High Speed Ground | 28 | BL_PWR | Backlight power (5V~21V) |
| 9 | AUX_CH_P | True Signal Auxiliary Ch. | 29 | BL_PWR | Backlight power (5V~21V) |
| 10 | AUX_CH_N | Comp Signal Auxiliary Ch. | 30 | NC | No Connect (Reserved for CM) |
| 11 | H_GND | High Speed Ground | 31 | TP_D- | Reserved for USB DATA- For Touch |
| 12 | LCD_VCC | LCD logic and driver power | 32 | TP_D+ | Reserved for USB DATA+ For Touch |
| 13 | LCD_VCC | LCD logic and driver power | 33 | GND | Ground Shield |
| 14 | LCD_Self_Test or NC | LCD Panel Self Test Enable (Optional) | 34 | VTSP | Touch panel power supply (3.3V) |
| 15 | LCD_GND | LCD logic and driver ground | 35 | VTSP | Touch panel power supply (3.3V) |
| 16 | LCD_GND | LCD logic and driver ground | 36 | TP_EN | Touch Function Enable Pin |
| 17 | HPD | HPD signal pin | 37 | TP_CLK | I2C Clock for Touch |
| 18 | BL_GND | Backlight ground | 38 | TP_Data | I2C Data for Touch |
| 19 | BL_GND | Backlight ground | 39 | INT | Interrupt for Touch |
| 20 | BL_GND | Backlight ground | 40 | RST | Reset for Touch |

5.2 eDP Interface

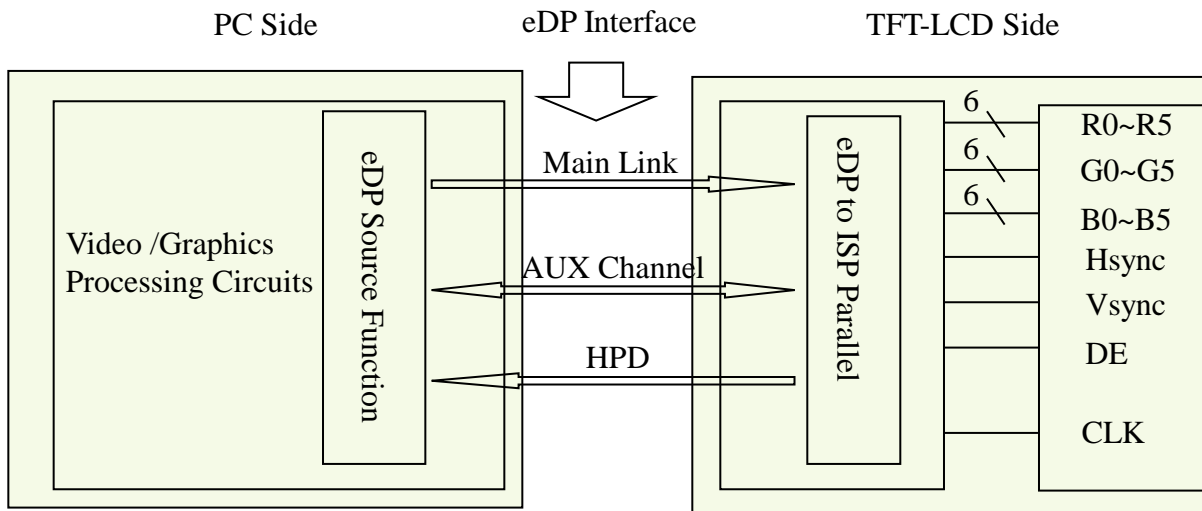

Figure 13. eDP Interface Architecture

Note:

Transmitter : Parade DP501 or equivalent.

Transmitter is not contained in module.

5.3 Data Input Format

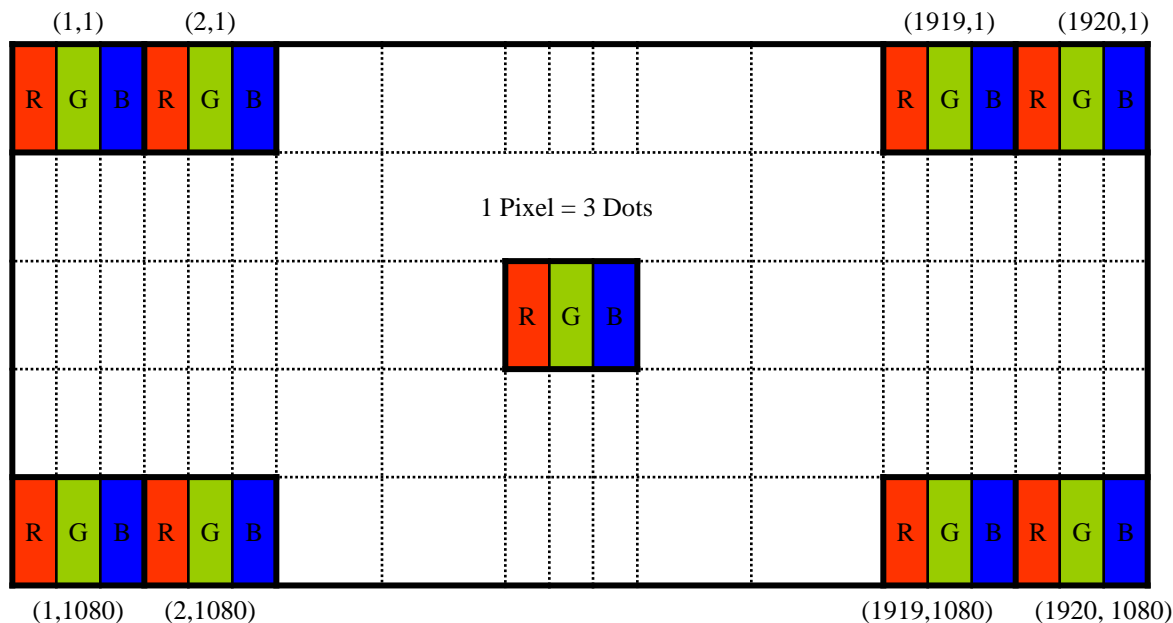

Figure 14. Display Position of Input Data (V-H)

5.4 Back-light & LCM Interface Connection

BLU Interface Connector: STM MSK24022P10.

<Table 7. Pin Assignments for the BLU Connector>

| Pin No. | Symbol | Description | Pin No. | Symbol | Description |
|---------|--------|----------------------|---------|--------|------------------------|
| 1 | Vout | LED anode connection | 6 | NC | NC Connection |
| 2 | Vout | LED anode connection | 7 | LED1 | LED cathode connection |
| 3 | Vout | LED anode connection | 8 | LED2 | LED cathode connection |
| 4 | NC | NC | 9 | LED3 | LED cathode connection |
| 5 | NC | NC | 10 | LED4 | LED cathode connection |

6.0 SIGNAL TIMING SPECIFICATION**6.1 The NV156FHM-T06 Is Operated By The DE Only**

< Table 8. Signal Timing Specification >

| Item | | Symbols | Min | Typ | Max | Unit |
|---------------------------|-----------|---------|-------|-------|-------|--------|
| Clock | Frequency | 1/Tc | 138.9 | 142.9 | 146.6 | MHz |
| Frame Period | | Tv | 1092 | 1100 | 1174 | lines |
| | | | - | 60 | - | Hz |
| | | | - | 16.67 | - | ms |
| Vertical Display Period | | Tvd | - | 1080 | - | lines |
| One line Scanning Period | | Th | 2120 | 2142 | 2225 | clocks |
| Horizontal Display Period | | Thd | - | 1920 | - | clocks |

Note : The above is as optimized setting.

6.2 eDP Rx Interface Timing Parameter

The specification of the eDP Rx interface timing parameter is shown in Table 9.1

<Table 9. eDP Main-Link RX TP4 Package Pin Parameters>

| Item | Symbol | Min | Typ | Max | Unit | Remark |
|---|---------------------|-----|-----|------|----------|--------|
| Spread spectrum clock (Link clock down-spreading) | ssc | 0 | - | 0.5 | % | |
| Differential peak-to-peak input voltage at package pins | VRX-DIFFp-p | 100 | - | 1320 | mV | |
| Rx input DC common mode voltage | VRX_DC_CM | 0 | - | 2 | V | |
| Differential termination resistance | RRX-DIFF | 80 | 100 | 120 | Ω | |
| Single-ended termination resistance | RRX-SE | 40 | - | 60 | Ω | |
| Rx short circuit current limit | IRX_SHORT | - | - | 50 | mA | |
| Intra-pair skew at Rx package pins (HBR) RX intra-pair skew tolerance at HBR | LRX_SKEW_INTRA_PAIR | - | - | 60 | ps | |

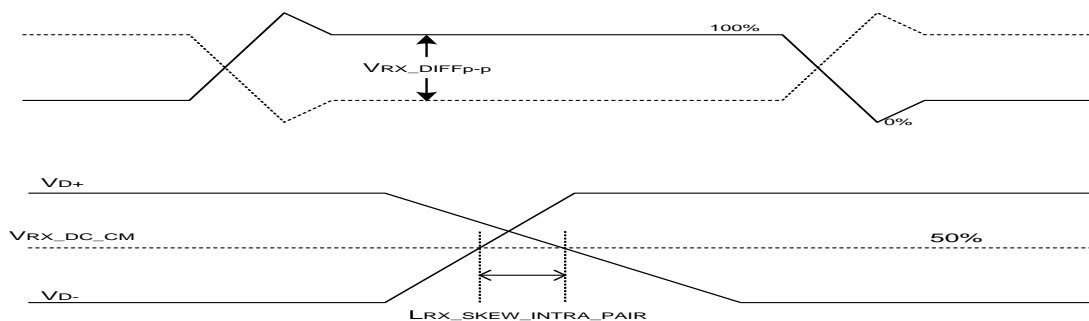
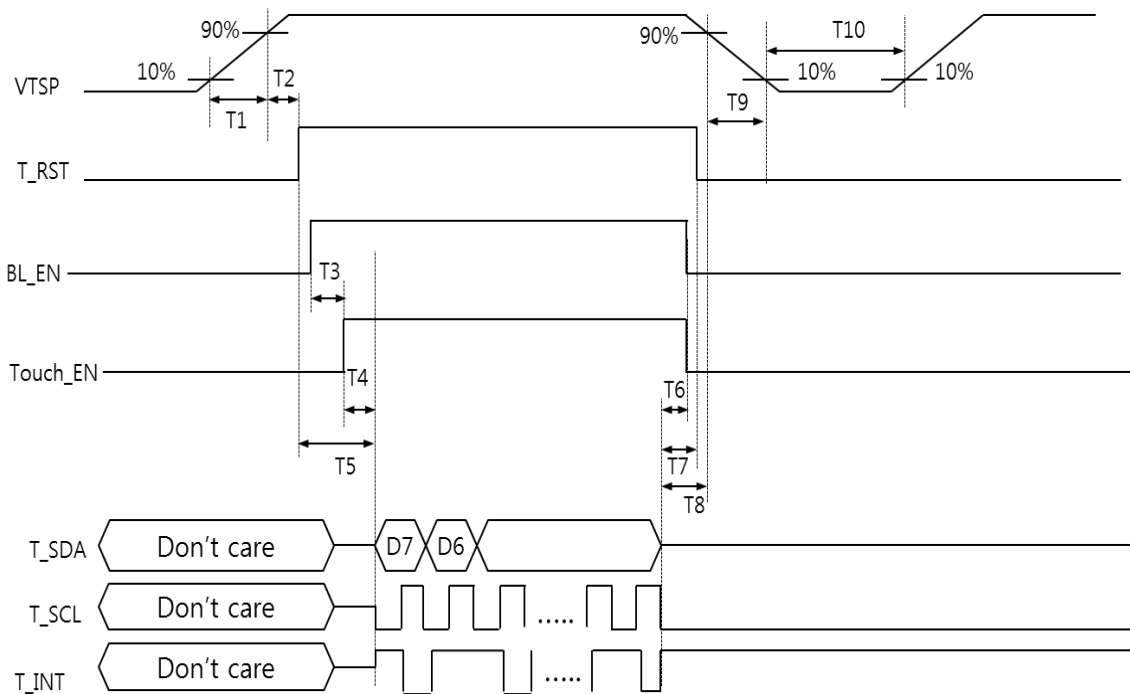

Figure 15. $VRX_DIFFp-p$ & $LRX_SKEW_INTRA_PAIR$

6.3 Touch Interface Timing Parameter

The specification of the Touch interface timing parameter is shown in Table 9.2

<Table 10.2 Touch Interface Timing Specification>



- 0ms ≤ T1
- 400us ≤ T2
- 0ms ≤ T3 ≤ 50ms
- 325ms ≤ T4
- 425ms ≤ T5
- 0ms ≤ T6
- 5ms ≤ T7/T8
- 50us ≤ T9
- 12us ≤ T10

7.0 INPUT SIGNALS, BASIC DISPLAY COLORS & GRAY SCALE OF COLORS

<Table 10. Input Signal & Basic Display Colors & Gray Scale of Colors >

| | Colors & Gray scale | Data signal | | | | | | | | | | | | | | | | | |
|-----------------------------|---------------------|-------------|----|----|----|----|----|----|----|----|----|----|----|----|----|----|----|----|----|
| | | R0 | R1 | R2 | R3 | R4 | R5 | G0 | G1 | G2 | G3 | G4 | G5 | B0 | B1 | B2 | B3 | B4 | B5 |
| Basic colors | Black | 0 | 0 | 0 | 0 | 0 | 0 | 0 | 0 | 0 | 0 | 0 | 0 | 0 | 0 | 0 | 0 | 0 | 0 |
| | Blue | 0 | 0 | 0 | 0 | 0 | 0 | 0 | 0 | 0 | 0 | 0 | 0 | 1 | 1 | 1 | 1 | 1 | 1 |
| | Green | 0 | 0 | 0 | 0 | 0 | 0 | 1 | 1 | 1 | 1 | 1 | 1 | 0 | 0 | 0 | 0 | 0 | 0 |
| | Light Blue | 0 | 0 | 0 | 0 | 0 | 0 | 1 | 1 | 1 | 1 | 1 | 1 | 1 | 1 | 1 | 1 | 1 | 1 |
| | Red | 1 | 1 | 1 | 1 | 1 | 1 | 0 | 0 | 0 | 0 | 0 | 0 | 0 | 0 | 0 | 0 | 0 | 0 |
| | Purple | 1 | 1 | 1 | 1 | 1 | 1 | 0 | 0 | 0 | 0 | 0 | 0 | 1 | 1 | 1 | 1 | 1 | 1 |
| | Yellow | 1 | 1 | 1 | 1 | 1 | 1 | 1 | 1 | 1 | 1 | 1 | 1 | 0 | 0 | 0 | 0 | 0 | 0 |
| | White | 1 | 1 | 1 | 1 | 1 | 1 | 1 | 1 | 1 | 1 | 1 | 1 | 1 | 1 | 1 | 1 | 1 | 1 |
| Gray scale of Red | Black | 0 | 0 | 0 | 0 | 0 | 0 | 0 | 0 | 0 | 0 | 0 | 0 | 0 | 0 | 0 | 0 | 0 | 0 |
| | △ | 1 | 0 | 0 | 0 | 0 | 0 | 0 | 0 | 0 | 0 | 0 | 0 | 0 | 0 | 0 | 0 | 0 | 0 |
| | Darker | 0 | 1 | 0 | 0 | 0 | 0 | 0 | 0 | 0 | 0 | 0 | 0 | 0 | 0 | 0 | 0 | 0 | 0 |
| | △ | | | | | | | | | | | | | | | | | | |
| | ▽ | | | | | | | | | | | | | | | | | | |
| | Brighter | 1 | 0 | 1 | 1 | 1 | 1 | 0 | 0 | 0 | 0 | 0 | 0 | 0 | 0 | 0 | 0 | 0 | 0 |
| Gray scale of Green | Black | 0 | 0 | 0 | 0 | 0 | 0 | 0 | 0 | 0 | 0 | 0 | 0 | 0 | 0 | 0 | 0 | 0 | 0 |
| | △ | 0 | 0 | 0 | 0 | 0 | 0 | 1 | 0 | 0 | 0 | 0 | 0 | 0 | 0 | 0 | 0 | 0 | 0 |
| | Darker | 0 | 0 | 0 | 0 | 0 | 0 | 0 | 1 | 0 | 0 | 0 | 0 | 0 | 0 | 0 | 0 | 0 | 0 |
| | △ | | | | | | | | | | | | | | | | | | |
| | ▽ | | | | | | | | | | | | | | | | | | |
| | Brighter | 0 | 0 | 0 | 0 | 0 | 0 | 1 | 0 | 1 | 1 | 1 | 1 | 0 | 0 | 0 | 0 | 0 | 0 |
| Gray scale of Blue | Black | 0 | 0 | 0 | 0 | 0 | 0 | 0 | 0 | 0 | 0 | 0 | 0 | 0 | 0 | 0 | 0 | 0 | 0 |
| | △ | 0 | 0 | 0 | 0 | 0 | 0 | 0 | 0 | 0 | 0 | 0 | 0 | 1 | 0 | 0 | 0 | 0 | 0 |
| | Darker | 0 | 0 | 0 | 0 | 0 | 0 | 0 | 0 | 0 | 0 | 0 | 0 | 0 | 1 | 0 | 0 | 0 | 0 |
| | △ | | | | | | | | | | | | | | | | | | |
| | ▽ | | | | | | | | | | | | | | | | | | |
| | Brighter | 0 | 0 | 0 | 0 | 0 | 0 | 0 | 0 | 0 | 0 | 0 | 0 | 1 | 0 | 1 | 1 | 1 | 1 |
| Gray scale of White & Black | Black | 0 | 0 | 0 | 0 | 0 | 0 | 0 | 0 | 0 | 0 | 0 | 0 | 0 | 0 | 0 | 0 | 0 | 0 |
| | △ | 1 | 0 | 0 | 0 | 0 | 0 | 1 | 0 | 0 | 0 | 0 | 0 | 1 | 0 | 0 | 0 | 0 | 0 |
| | Darker | 0 | 1 | 0 | 0 | 0 | 0 | 0 | 1 | 0 | 0 | 0 | 0 | 0 | 1 | 0 | 0 | 0 | 0 |
| | △ | | | | | | | | | | | | | | | | | | |
| | ▽ | | | | | | | | | | | | | | | | | | |
| | Brighter | 1 | 0 | 1 | 1 | 1 | 1 | 1 | 0 | 1 | 1 | 1 | 1 | 1 | 0 | 1 | 1 | 1 | 1 |
| White | 1 | 1 | 1 | 1 | 1 | 1 | 1 | 1 | 1 | 1 | 1 | 1 | 1 | 1 | 1 | 1 | 1 | 1 | |

8.0 POWER SEQUENCE

To prevent a latch-up or DC operation of the LCD module, the power on/off sequence shall be as shown in below.

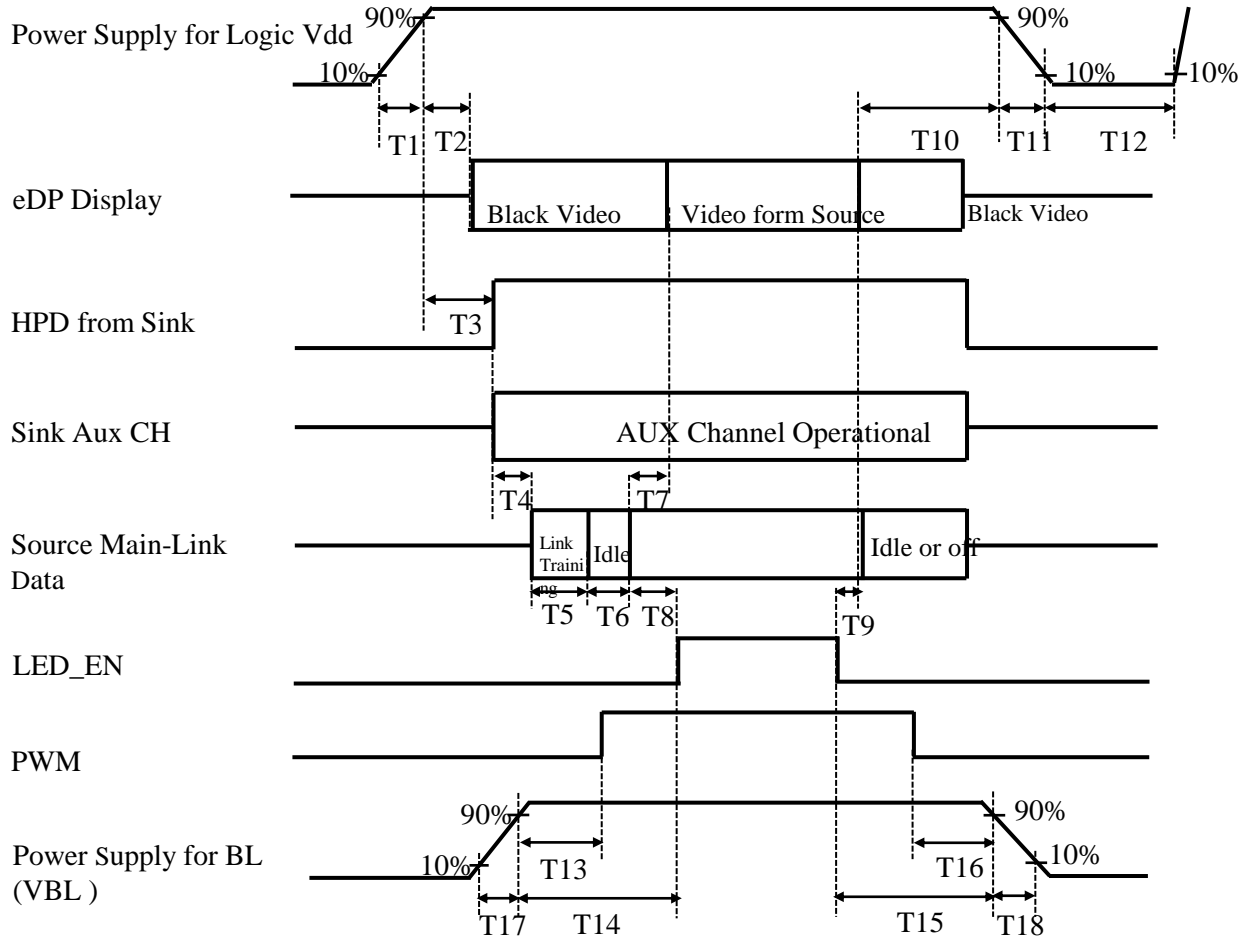

Figure 16. Power Sequence

- 0.5ms ≤ T1 ≤ 10 ms
- 0ms < T2 ≤ 200 ms
- 0ms < T3 ≤ 200 ms
- T3+T4+T5+T6+T8>200ms
- 0ms < T7 ≤ 50ms
- 50ms < T8
- 0ms < T9
- 0ms < T10 < 500 ms
- 0.5ms ≤ T11 ≤ 10 ms
- 500ms ≤ T12
- 0ms < T13
- 0ms < T14
- 0ms < T15
- 0ms < T16
- 0.5ms ≤ T17
- 0.5ms ≤ T18

Notes:

1. When the power supply VDD is 0V, keep the level of input signals on the low or keep high impedance.
2. Do not keep the interface signal high impedance when power is on. Back Light must be turn on after power for logic and interface signal are valid.

9.0 Connector Description

Physical interface is described as for the connector on LCM.

These connectors are capable of accommodating the following signals and will be following components.

9.1 TFT LCD Module

< Table 11. Signal Connector >

| Connector Name /Description | For Signal Connector |
|-----------------------------|----------------------|
| Manufacturer | IPEX |
| Type/ Part Number | 20455-040E-66 |
| Mating Housing/ Part Number | 20454-30T |

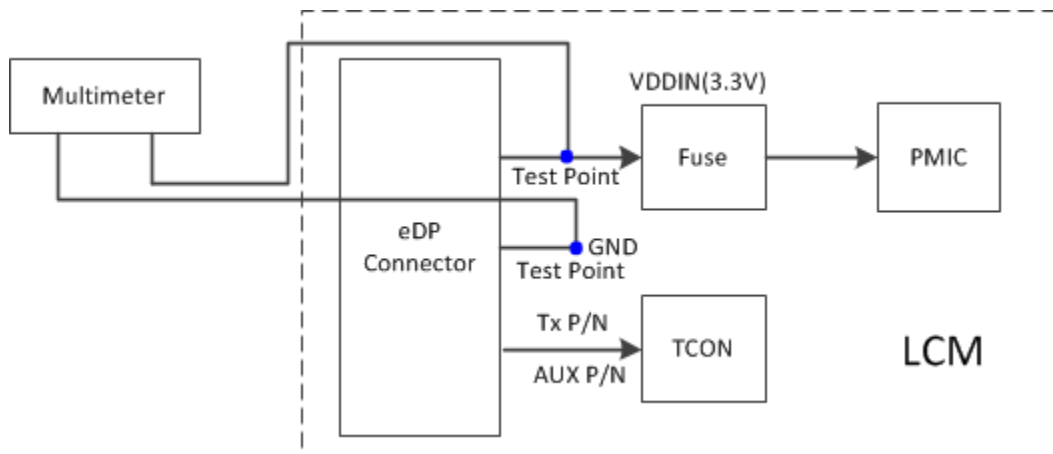
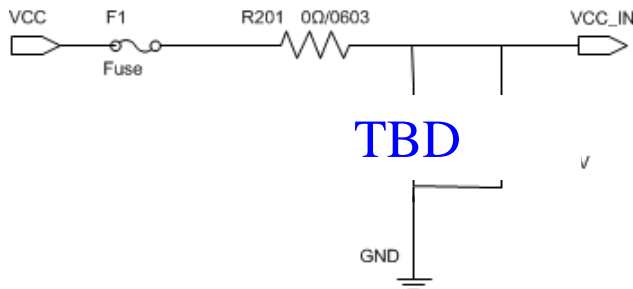

Figure 17. RC Loading test schematic diagram



TBD

| Item | RC Loading | |
|------|------------|---|
| | R | C |
| | TBD | |

Figure 18. VCC Loop R/C Loading Parameter

10.0 MECHANICAL CHARACTERISTICS

10.1 Dimensional Requirements

Figure 23 shows mechanical outlines for the model NV156FHM-T06.
Other parameters are shown in Table 12.

<Table 12. Dimensional Parameters>

| Parameter | Specification | Unit |
|---------------------|---|--------|
| Active Area | 344.16 (H) × 193.59 (V) | mm |
| Number of pixels | 1920 (H) X 1080 (V) (1 pixel = R + G + B dots) | pixels |
| Pixel pitch | 179.25 (H) X 179.25 (V) | um |
| Pixel arrangement | RGB Vertical stripe | |
| Display colors | 262K(6bit) | |
| Display mode | Normally Black | |
| Dimensional outline | 350.66(H) × 216.15(V) (W/PCB) × 3.2max(panel side) 3.4max(PCBA side) | mm |
| Weight | 385 (max) | g |

10.2 Mounting

See Figure 20.

10.3 Glare and Polarizer Hardness.

The surface of the LCD has a Glare coating to minimize reflection and to reduce scratching.

10.4 Light Leakage

There shall not be visible light from the back-lighting system around the edges of the screen as seen from a distance 50cm from the screen with an overhead light level of 350lux.

11.0 RELIABILITY TEST

The reliability test items and its conditions are shown in below.

<Table 13. Reliability Test>

| No | Test Items | Conditions |
|----|---|--|
| 1 | High temperature storage test | Ta = 60° C , 60%RH, 240 hrs |
| 2 | Low temperature storage test | Ta = -20° C , 240 hrs |
| 3 | High temperature & high humidity operation test | Ta = 50° C , 80%RH, 240 hrs |
| 4 | High temperature operation test | Ta = 50° C , 60%RH, 240 hrs |
| 5 | Low temperature operation test | Ta = 0° C , 240 hrs |
| 6 | Thermal shock | Ta = -20° C ↔ 60° C (0.5 hr), 60% ±3%RH, 100 cycle |
| 7 | Vibration test (non-operating) | Ta = 25° C , 60%RH, 1.5G, 10~500Hz, Half Sine X,Y,Z / Sweep rate : 1 hour |
| 8 | Shock test (non-operating) | Ta = 25° C , 60%RH, 220G, Half Sine Wave 2msec±X,±Y,±Z Once for each direction |
| 9 | Electro-static discharge test (operating) | Air : 150 pF, 330Ω, ±15 KV Contact : 150 pF, 330Ω, ±8 KV Ta = 25° C , 60%RH, |

12.0 HANDLING & CAUTIONS

(1) Cautions when taking out the module

- Pick the pouch only, when taking out module from a shipping package.

(2) Cautions for handling the module

- As the electrostatic discharges may break the LCD module, handle the LCD module with care. Peel a protection sheet off from the LCD panel surface as slowly as possible.
- As the LCD panel and back - light element are made from fragile glass material, impulse and pressure to the LCD module should be avoided.
- As the surface of the polarizer is very soft and easily scratched, use a soft dry cloth without chemicals for cleaning.
- Do not pull the interface connector in or out while the LCD module is operating.
- Put the module display side down on a flat horizontal plane.
- Handle connectors and cables with care.

(3) Cautions for the operation

- When the module is operating, do not lose CLK, ENAB signals. If any one of these signals is lost, the LCD panel would be damaged.
- Obey the supply voltage sequence. If wrong sequence is applied, the module would be damaged.

(4) Cautions for the atmosphere

- Dew drop atmosphere should be avoided.
- Do not store and/or operate the LCD module in a high temperature and/or humidity atmosphere. Storage in an electro-conductive polymer packing pouch and under relatively low temperature atmosphere is recommended.

(5) Cautions for the module characteristics

- Do not apply fixed pattern data signal to the LCD module at product aging.
- Applying fixed pattern for a long time may cause image sticking.

(6) Other cautions

- Do not disassemble and/or re-assemble LCD module.
- Do not re-adjust variable resistor or switch etc.
- When returning the module for repair or etc. Please pack the module not to be broken. We recommend to use the original shipping packages.

13.0 LABEL

(1) Product Label



Figure 16. Product Label

Module ID Naming Rule:

<Table 14. Module ID Naming Rule>

| Digit | 1 | 2 | 3 | 4 | 5 | 6 | 7 | 8 | 9 | 10 | 11 | 12 | 13 | 14 | 15 | 16 | 17 |
|-------------|-----------------|---|-------|------|------|---|-------|--|---|----|----|------------------------|----|----|----|----|----|
| Code | S | L | S | 5 | 1 | 2 | 3 | 5 | 9 | 4 | 2 | 0 | 0 | 0 | 1 | D | B |
| Description | Model Code /GBN | | Grade | Line | Year | | Month | Model Extension Code (Last 4 Digits Of FGCD) | | | | Serial No 00001-ZZZZZZ | | | | | |

(2) High voltage caution label

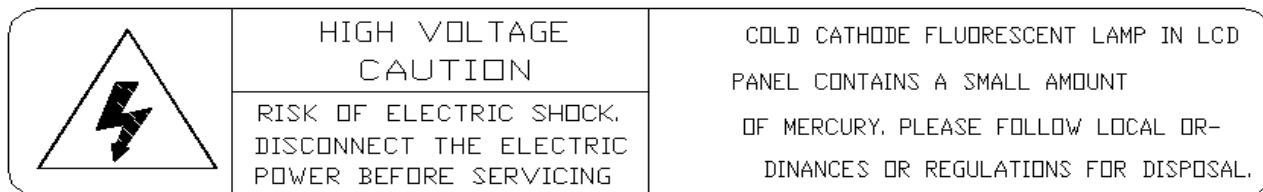

Figure 17. High Voltage Caution Label

(3) Box Label

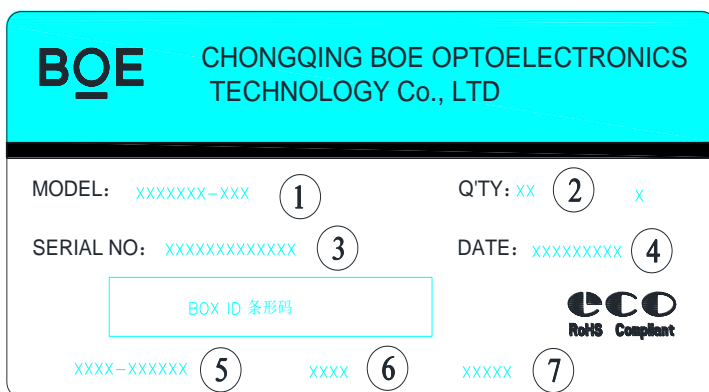

Figure 18. Box Label

Serial number marked part needs to print, show as follows:

1. FG-CODE(Before 12 bit)
2. Product quantity
3. Box ID
4. Date
5. The client section material number(The client)
6. FG-Code After four
7. The supplier code
8. Total Size:100×50mm

<Table 15. Box Label Naming Rule >

| Digit | 1 | 2 | 3 | 4 | 5 | 6 | 7 | 8 | 9 | 10 | 11 | 12 | 13 |
|-------------|--------------|---|-------|------|------|---|-------|---------------|-----------|----|----|----|----|
| Code | S | L | S | F | 1 | 2 | 3 | D | 0 | 0 | 0 | 6 | 8 |
| Description | Products GBN | | Grade | Line | Year | | Month | Revision Code | Serial No | | | | |

14.0 PACKING INFORMATION

14.1 Packing Order

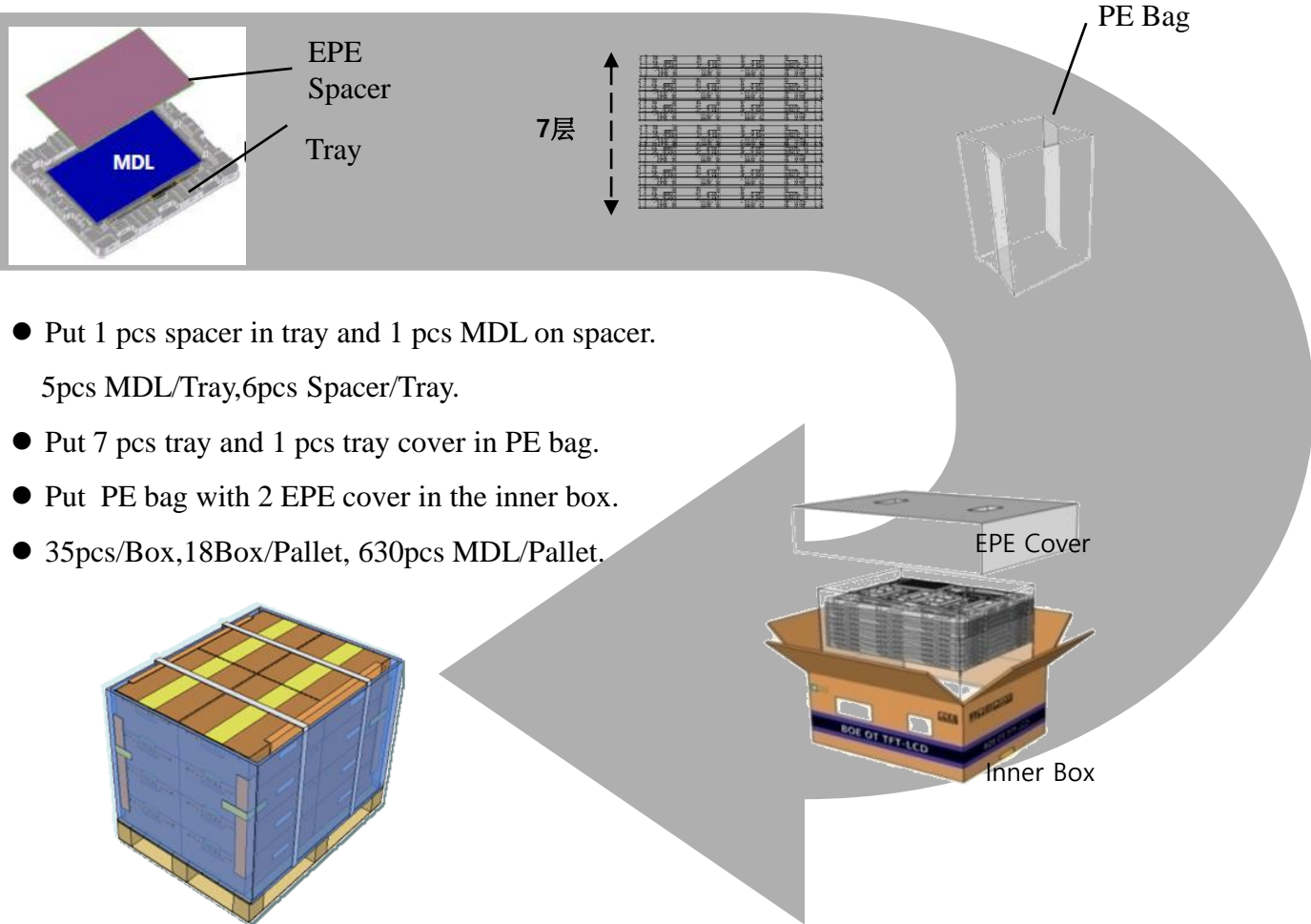

Figure 19. Packing Order

14.2 Note

- Box dimension: 480mm*350mm*285mm
- Package quantity in one box: 35pcs
- Total weight: TBD

15.0 MECHANICAL OUTLINE DIMENSION

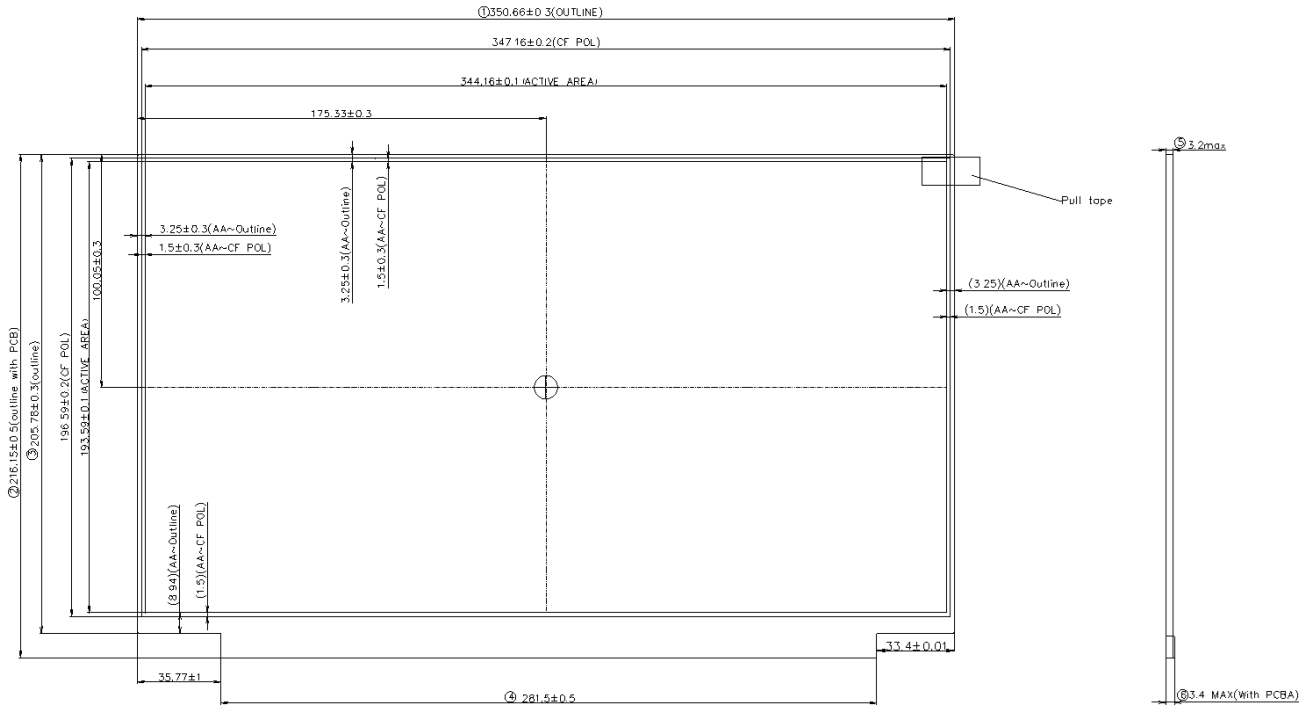

Figure 20. TFT-LCD Module Outline Dimension (Front View)

Note:

1. Warps And Deformation spec 0.5mm Max.
2. EDP connector is measured at PIN 1 and MATING LINE.
3. Key dimensions: ① -⑧
4. The MDL dimensions measure tool is Vernier Caliper.
5. Top Pol must be the highest portion in bottom including PCBA.

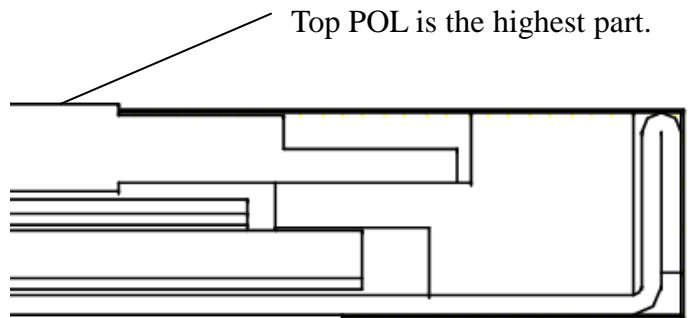

Figure 21. Highest Point Position

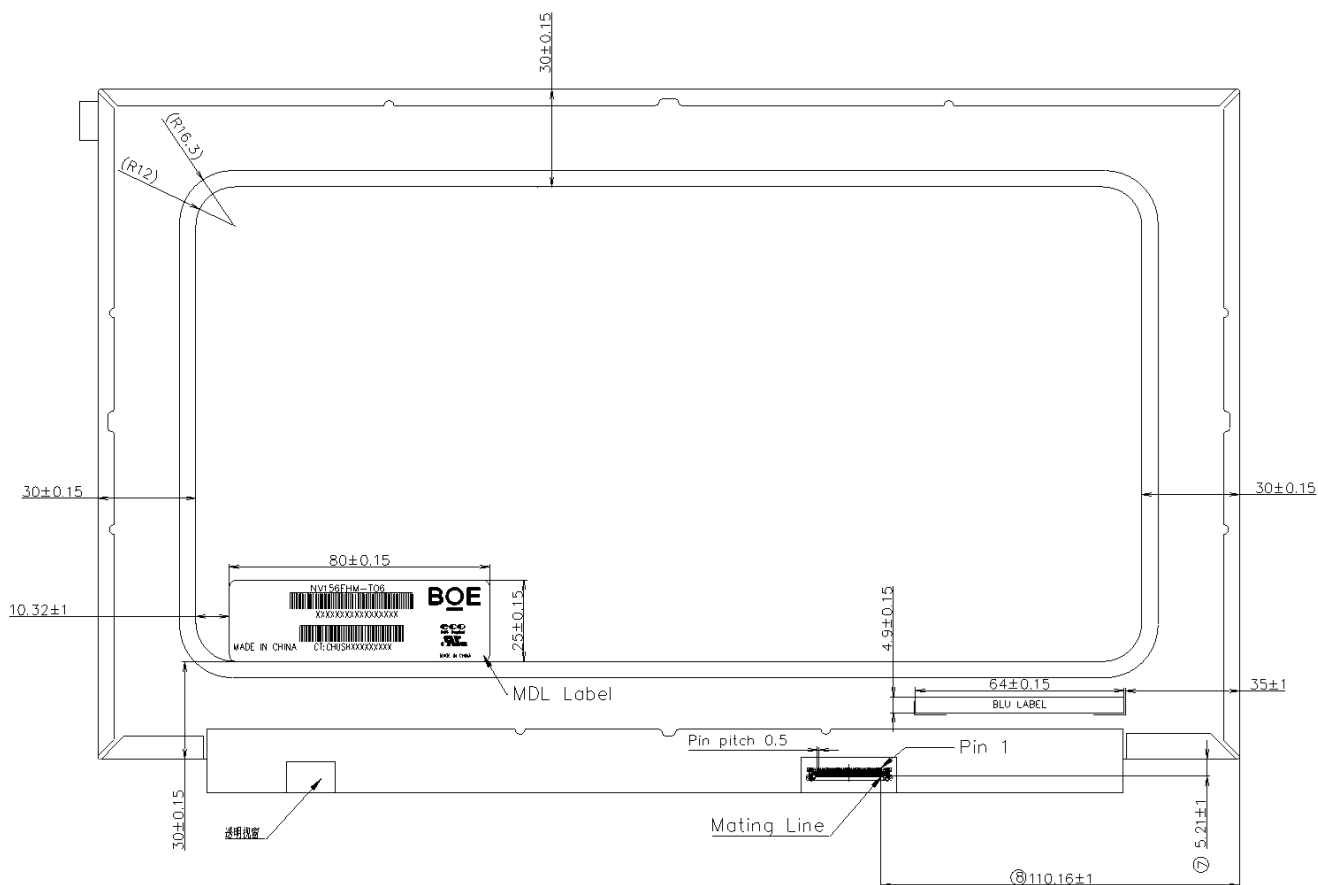

Figure 22. TFT-LCD Module Outline Dimensions (Rear view)

Note:

1. Warps And Deformation spec 0.5mm Max.
2. EDP connector is measured at PIN 1 and MATING LINE.
3. Key dimensions: ① -⑧
4. The MDL dimensions measure tool is Vernier Caliper.
5. Top Pol must be the highest portion in bottom including PCBA.

16.0 EDID Table

| Address (HEX) | Function | Hex | Dec | Input Values | Notes | |
|---------------|------------------------|-----|-----|--------------|-----------------------|------------------------------|
| 00 | Header | 00 | 0 | 0 | EDID Header | |
| 01 | | FF | 255 | 255 | | |
| 02 | | FF | 255 | 255 | | |
| 03 | | FF | 255 | 255 | | |
| 04 | | FF | 255 | 255 | | |
| 05 | | FF | 255 | 255 | | |
| 06 | | FF | 255 | 255 | | |
| 07 | | 00 | 0 | 0 | | |
| 08 | ID Manufacturer Name | 09 | 9 | BOE | ID = BOE | |
| 09 | | E5 | 229 | | | |
| 0A | ID Product Code | 3D | 61 | 2109 | ID = 2109 | |
| 0B | | 08 | 8 | | | |
| 0C | 32-bit serial No. | 00 | 0 | 0 | | |
| 0D | | 00 | 0 | 0 | | |
| 0E | | 00 | 0 | 0 | | |
| 0F | | 00 | 0 | 0 | | |
| 10 | Week of manufacture | 01 | 1 | 1 | | |
| 11 | Year of Manufacture | 1C | 28 | 2018 | Manufactured in 2018 | |
| 12 | EDID Structure Ver. | 01 | 1 | 1 | EDID Ver 1.0 | |
| 13 | EDID revision # | 04 | 4 | 4 | EDID Rev. 0.4 | |
| 14 | Video input definition | 95 | 149 | - | Refer to right table | |
| 15 | Max H image size | 22 | 34 | 34 | 34.416 cm (Approx) | |
| 16 | Max V image size | 13 | 19 | 19 | 19.359 cm (Approx) | |
| 17 | Display Gamma | 78 | 120 | 2.2 | Gamma curve = 2.2 | |
| 18 | Feature support | 03 | 3 | - | Refer to right table | |
| 19 | Red/Green low bits | 24 | 36 | - | Red / Green Low Bits | |
| 1A | Blue/White low bits | 10 | 16 | - | Blue / White Low Bits | |
| 1B | Red x high bits | 97 | 151 | 604 | 0.590 | Red (x) = 10010111 (0.59) |
| 1C | Red y high bits | 59 | 89 | 358 | 0.350 | Red (y) = 01011001 (0.35) |
| 1D | Green x high bits | 54 | 84 | 337 | 0.330 | Green (x) = 01010100 (0.33) |
| 1E | Green y high bits | 8E | 142 | 568 | 0.555 | Green (y) = 10001110 (0.555) |
| 1F | Blue x high bits | 27 | 39 | 156 | 0.153 | Blue (x) = 00100111 (0.153) |
| 20 | Blue y high bits | 1E | 30 | 121 | 0.119 | Blue (y) = 00011110 (0.119) |
| 21 | White x high bits | 50 | 80 | 320 | 0.313 | White (x) = 01010000 (0.313) |
| 22 | White y high bits | 54 | 84 | 336 | 0.329 | White (y) = 01010100 (0.329) |
| 23 | Established timing 1 | 00 | 0 | - | Refer to right table | |
| 24 | Established timing 2 | 00 | 0 | - | | |
| 25 | Established timing 3 | 00 | 0 | - | | |

| | | | | | | | |
|----|---------------------------------------|----|-----|---|----------------------|-------------------------|---|
| 26 | Standard timing #1 | 01 | 1 | | | Not Used | |
| 27 | | 01 | 1 | | | | |
| 28 | Standard timing #2 | 01 | 1 | | | Not Used | |
| 29 | | 01 | 1 | | | | |
| 2A | Standard timing #3 | 01 | 1 | | | Not Used | |
| 2B | | 01 | 1 | | | | |
| 2C | Standard timing #4 | 01 | 1 | | | Not Used | |
| 2D | | 01 | 1 | | | | |
| 2E | Standard timing #5 | 01 | 1 | | | Not Used | |
| 2F | | 01 | 1 | | | | |
| 30 | Standard timing #6 | 01 | 1 | | | Not Used | |
| 31 | | 01 | 1 | | | | |
| 32 | Standard timing #7 | 01 | 1 | | | Not Used | |
| 33 | | 01 | 1 | | | | |
| 34 | Standard timing #8 | 01 | 1 | | | Not Used | |
| 35 | | 01 | 1 | | | | |
| 36 | Detailed timing/monitor descriptor #1 | D3 | 211 | | 142.9 | 142.91424MHz Main clock | |
| 37 | | 37 | 55 | | | | |
| 38 | | 80 | 128 | | 1920 | | Hor Active = 1920 |
| 39 | | DE | 222 | | 222 | | Hor Blanking = 222 |
| 3A | | 70 | 112 | | - | | 4 bits of Hor. Active + 4 bits of Hor. Blanking |
| 3B | | 38 | 56 | | 1080 | | Ver Active = 1080 |
| 3C | | 20 | 32 | | 32 | | Ver Blanking = 32 |
| 3D | | 40 | 64 | | - | | 4 bits of Ver. Active + 4 bits of Ver. Blanking |
| 3E | | 30 | 48 | | 48 | | Hor Sync Offset = 48 |
| 3F | | 20 | 32 | | 32 | | H Sync Pulse Width = 32 |
| 40 | | 36 | 54 | | 3 | | V sync Offset = 3 line |
| 41 | | 00 | 0 | | 6 | | V Sync Pulse width : 6 line |
| 42 | | 58 | 88 | | 344 | | Horizontal Image Size = 344.16 mm (Low 8 bits) |
| 43 | | C2 | 194 | | 194 | | Vertical Image Size = 193.59 mm (Low 8 bits) |
| 44 | | 10 | 16 | | - | | 4 bits of Hor Image Size + 4 bits of Ver Image Size |
| 45 | | 00 | 0 | | 0 | | Hor Border (pixels) |
| 46 | | 00 | 0 | | 0 | | Vertical Border (Lines) |
| 47 | 1A | 26 | | - | Refer to right table | | |

| | | | | | | |
|----|---------------------------------------|---------------------------------------|-----|---|------|--|
| 48 | Detailed timing/monitor descriptor #2 | 37 | 55 | | 95.3 | 95.27616MHz Main clock |
| 49 | | 25 | 37 | | | |
| 4A | | 80 | 128 | | 1920 | Hor Active = 1920 |
| 4B | | DE | 222 | | 222 | Hor Blanking = 222 |
| 4C | | 70 | 112 | | - | 4 bits of Hor. Active + 4 bits of Hor. Blanking |
| 4D | | 38 | 56 | | 1080 | Ver Active = 1080 |
| 4E | | 20 | 32 | | 32 | Ver Blanking = 32 |
| 4F | | 40 | 64 | | - | 4 bits of Ver. Active + 4 bits of Ver. Blanking |
| 50 | | 30 | 48 | | 48 | Hor Sync Offset = 48 |
| 51 | | 20 | 32 | | 32 | H Sync Pulse Width = 32 |
| 52 | | 36 | 54 | | 3 | V sync Offset = 3 line |
| 53 | | 00 | 0 | | 6 | V Sync Pulse width : 6 line |
| 54 | | 58 | 88 | | 344 | Horizontal Image Size = 344.16 mm (Low 8 bits) |
| 55 | | C2 | 194 | | 194 | Vertical Image Size = 193.59 mm (Low 8 bits) |
| 56 | | 10 | 16 | | - | 4 bits of Hor Image Size + 4 bits of Ver Image Size |
| 57 | | 00 | 0 | | 0 | Hor Border (pixels) |
| 58 | | 00 | 0 | | 0 | Vertical Border (Lines) |
| 59 | | 1A | 26 | | - | Refer to right above table |
| 5A | | Detailed timing/monitor descriptor #3 | 00 | 0 | | <p>Nvidia nvDPS (Refer the tab of nvDPS)</p> <p>Lowest refresh rate that does not cause any visual/optical side effect</p> |
| 5B | 00 | | 0 | | | |
| 5C | 00 | | 0 | | | |
| 5D | 00 | | 0 | | | |
| 5E | 00 | | 0 | | | |
| 5F | 00 | | 0 | | | |
| 60 | 00 | | 0 | | | |
| 61 | 00 | | 0 | | | |
| 62 | 00 | | 0 | | | |
| 63 | 00 | | 0 | | | |
| 64 | 00 | | 0 | | | |
| 65 | 00 | | 0 | | | |
| 66 | 00 | | 0 | | | |
| 67 | 00 | | 0 | | | |
| 68 | 00 | 0 | | | | |
| 69 | 00 | 0 | | | | |
| 6A | 00 | 0 | | | | |
| 6B | 00 | 0 | | | | |

| | | | | | | |
|----|---------------------------------------|----|-----|-----|---|--|
| 6C | Detailed timing/monitor descriptor #4 | 00 | 0 | | | Detailed Timing Description #4 |
| 6D | | 00 | 0 | | | Flag |
| 6E | | 00 | 0 | | | Reserved |
| 6F | | 02 | 2 | | | For Brightness Table and Power consumption |
| 70 | | 00 | 0 | | | Flag |
| 71 | | 0B | 11 | | - | PWM % [7:0] @ Step 0 |
| 72 | | 40 | 64 | | - | PWM % [7:0] @ Step 5 |
| 73 | | FF | 255 | | - | PWM % [7:0] @ step 10 |
| 74 | | 0A | 10 | | - | Nits [7:0] @ Step 0 |
| 75 | | 3C | 60 | | - | Nits [7:0] @ Step 5 |
| 76 | | 7D | 125 | | - | Nits [7:0] @ Step 10 |
| 77 | | 16 | 22 | | - | Panel Electronics Power @32x32 Chess Pattern = 900mW |
| 78 | | 16 | 22 | | - | Backlight Power @60 nits = 914.8mW |
| 79 | | 2D | 45 | | - | Backlight Power @Step 10 = 3600mW |
| 7A | | 7D | 125 | | - | Nits @ 100% PWM Duty = 250nit |
| 7B | | 00 | 0 | | | Format : terminate with ASCII code 0Ah and pad field with ASCII code 20h |
| 7C | 00 | 0 | | | | |
| 7D | 00 | 0 | | | | |
| 7E | Extension flag | 00 | 0 | | 1 | 0 : 1個EDID ; N-1 : N個EDID |
| 7F | Checksum | C2 | 194 | 194 | - | |